

Item	Description	HP Part No.
1	Screw (M3 x 0.5 x 16 mm)	0515- 0920
2	Screw (M2.5 x 0.45 x 16 mm)	0515- 0951
3	Valve	G1531-60540
4	Sensor lead	NA
5	Supply gas line	NA
6	Sensor board assembly	19245- 60025
7	EPC Mounting bracket	19245- 00170
8	Screws (2) (M3 x 0.5 x 8 mm)	0515- 0912
9	Gas outlet line	NA
10	Valve transducer block	19246- 20720
11	O- ring	
12	Nut with lockwasher	0535- 0043
13	Adapter cable for 2 channel sensor board	19245- 60702
	6 channel cable	19245-60970

**Figure 10. Auxiliary EPC Flow Module (Sheet 1 of 2).**

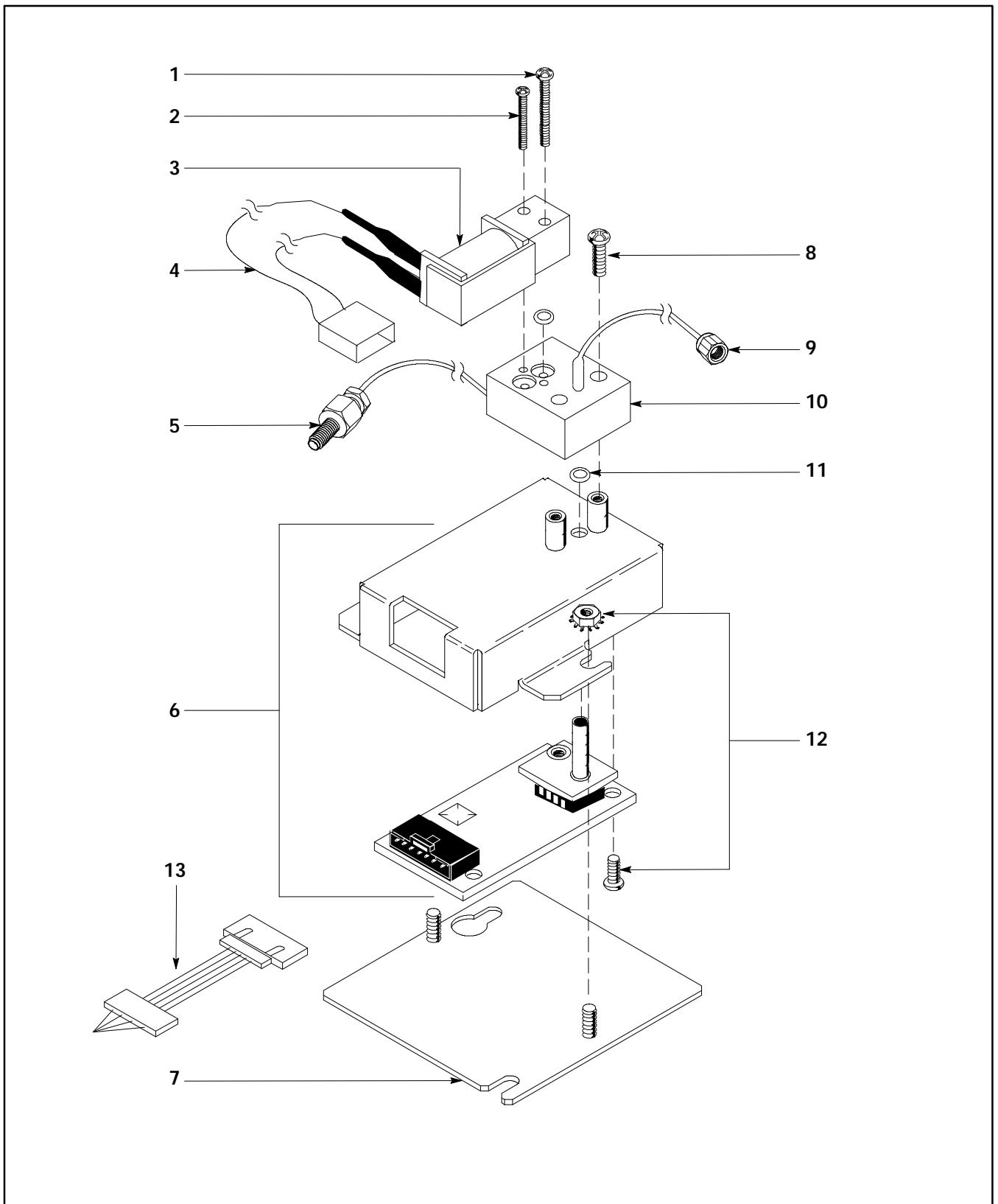

**Figure 10. Auxiliary EPC Flow Module (Sheet 2 of 2).**